



National Plastic Heater

Call Toll Free 1.877.674.9744

FUZZYLOGIC
TEMPERATURE CONTROLLER
OPERATION MANUAL

Before using please check whether range, input and output match your requirement.

Thank you for using our microprocessor temperature controller, we have obtained CE certification (LDV: D/N EN61010-1; EMC EN 55 022 1994/A1: 1995/A2: 1997, EN 61 000-3-2: 1995/ -3-3: 1995, EN 61 000-4-2: 1995/ -4-3: 1996/ -4-5: 1995/ -4-6: 1996/ -4-8: 1993/ -4-11: 1996/ EN 50 204: 1995) for all our products since January, 2002. We have also computerized our QC process and testing to provide high quality standard, low price and high functionality in our products.

1. Front panel instruction

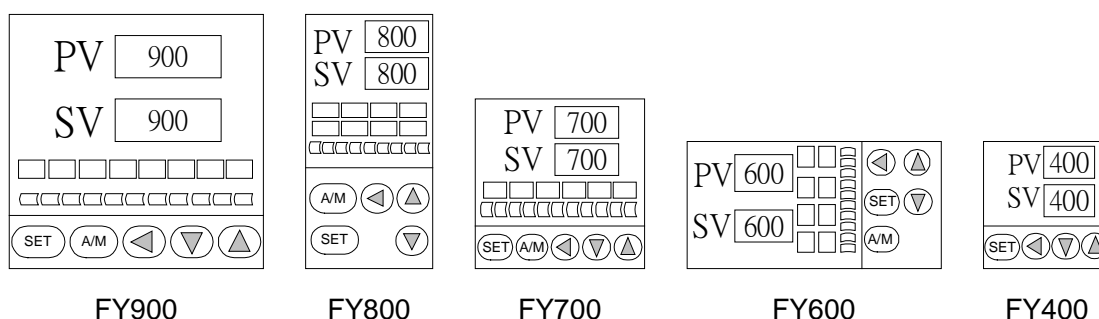

1.1 DISPLAY

PV : Process value , 4 digit display (red color)

SV : Setting value , 4 digit display (green color)

1.2 LED

OUT1 : Output 1 , green color

OUT2 : Output 2 , green color

AT : Auto Tuning , yellow color

PRO : Program , yellow color --- Only available for PFY models.

AL1 : Alarm 1 , red color

AL2 : Alarm 2 , red color

AL3 : Alarm 3 , red color

MAN : Manual , yellow color

*Note: When error occurs, the MAN will light up, and will reset output percentage to zero.

1.3 KEY

SET : MODE & SET key

◀ : SHIFT key

▽ : DOWN key (Setting value -1, -10, -100, -1000)

△ : UP key (Setting value +1, +10, +100, +1000)

A/M : Auto/Manual key.

Automatic : The output percentage is determined by internal calculation.

Manually : The output percentage is determined by manually set OUTL at User Level.

2 Auto tuning

2.2 Once AT is set YES , auto tuning is to be performed.

2.3 After auto tuning is finished , a new set of PID parameter is generated internally to replace the existing PID parameter.
* Auto tuning allows the controller to automatically adjust the PID parameter, and is suitable for use when temperature control is not accurate enough.

2.4 ATVL=auto tuning offset , and it will be deduced from SV
(it can prevent over shoot during auto tuning)
SV-ATVL=Auto-tuning value , ATVL=auto tuning offset
Ex.SV=200°C , ATVL=5 , Auto tuning point is at 195°C
During auto tuning the PV value will oscillate around 195°C.
Hence PV will not go over 200°C.

* In programmable model , ATVL means Auto-tuning point

2.5 Auto tuning failure

Possible Cause 1 : ATVL is too big. (If not sure , set ATVL=0)

Possible Cause 2 : System time is too long.(Set PID parameter individually)

3. Error information





DISPLAY	DESCRIPTION
IN1E	Open circuit of main control sensor.
* ADCF	A/D converter failed.
* CJCE	Cold junction compensation failed.
IN2E	Open circuit of sub control sensor.
UUU1	PV exceeds USPL.
NNN1	PV under LSPL.
UUU2	Input signal of sub control exceeds the upper limit.
NNN2	Input signal of sub control under the lower limit.
* RAMF	RAM failed.
INTF	Interface failed.
AUTF	Auto tuning failed.

NOTE : If the “*” marked error comes up , the Controller needs repair.
Please send it to the nearest sales office or retail dealer.

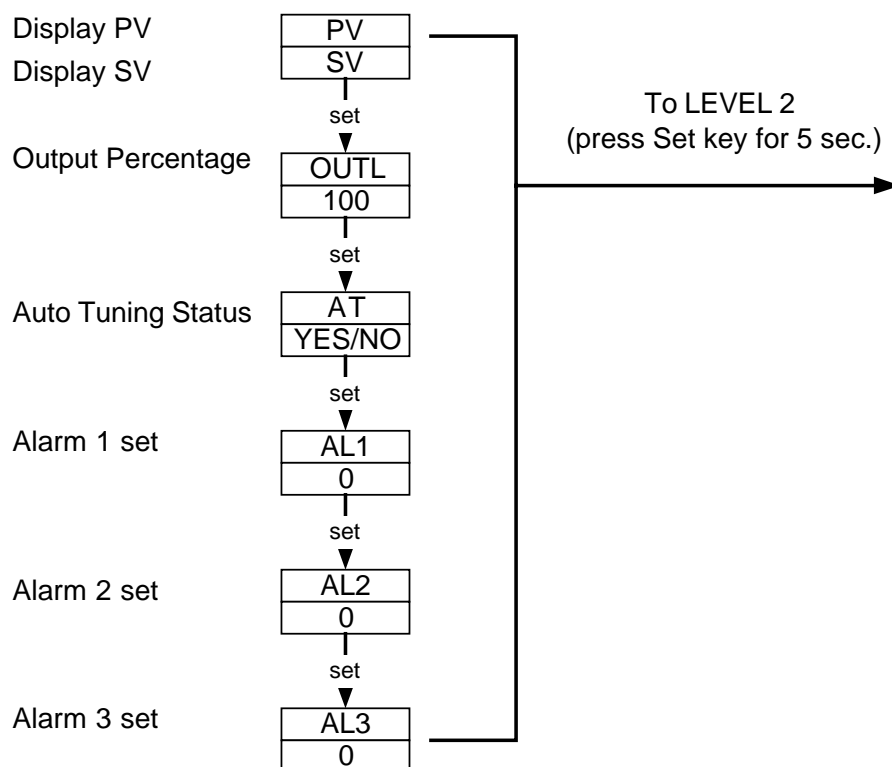
4. Operating flow

4.1 LEVEL 1 (User Level)



- 4.1.1 Press the **SHIFT KEY** () to change the parameters. If the **SHIFT KEY** is pressed, the first digit begins blinking. Press the **UP KEY** () or **DOWN KEY** () to increase or decrease the value of the digit, then press the **SHIFT KEY** () again to go to the next digit. As all the digit are written, press **SET KEY** to enter the value.
- 4.1.2 **SET KEY** also has the function of changing MODEs, if the **SET KEY** is pressed, the display shows the next MODE.
- 4.1.3 Press **SET KEY** for 5 sec. the display goes to LEVEL 2, and do the same thing to return LEVEL 1.
- 4.1.4 If any key were not pressed for 1 minute, the display would go to LEVEL 1.
- 4.1.5 Press **A/M KEY** the display to go to LEVEL 1, no matter where it is.
- 4.1.6 If **OUTL** set "0", it means the controller has no output,

4.2 LEVEL 2 (PID Level)

press SET key for 5 seconds to enter Level 2

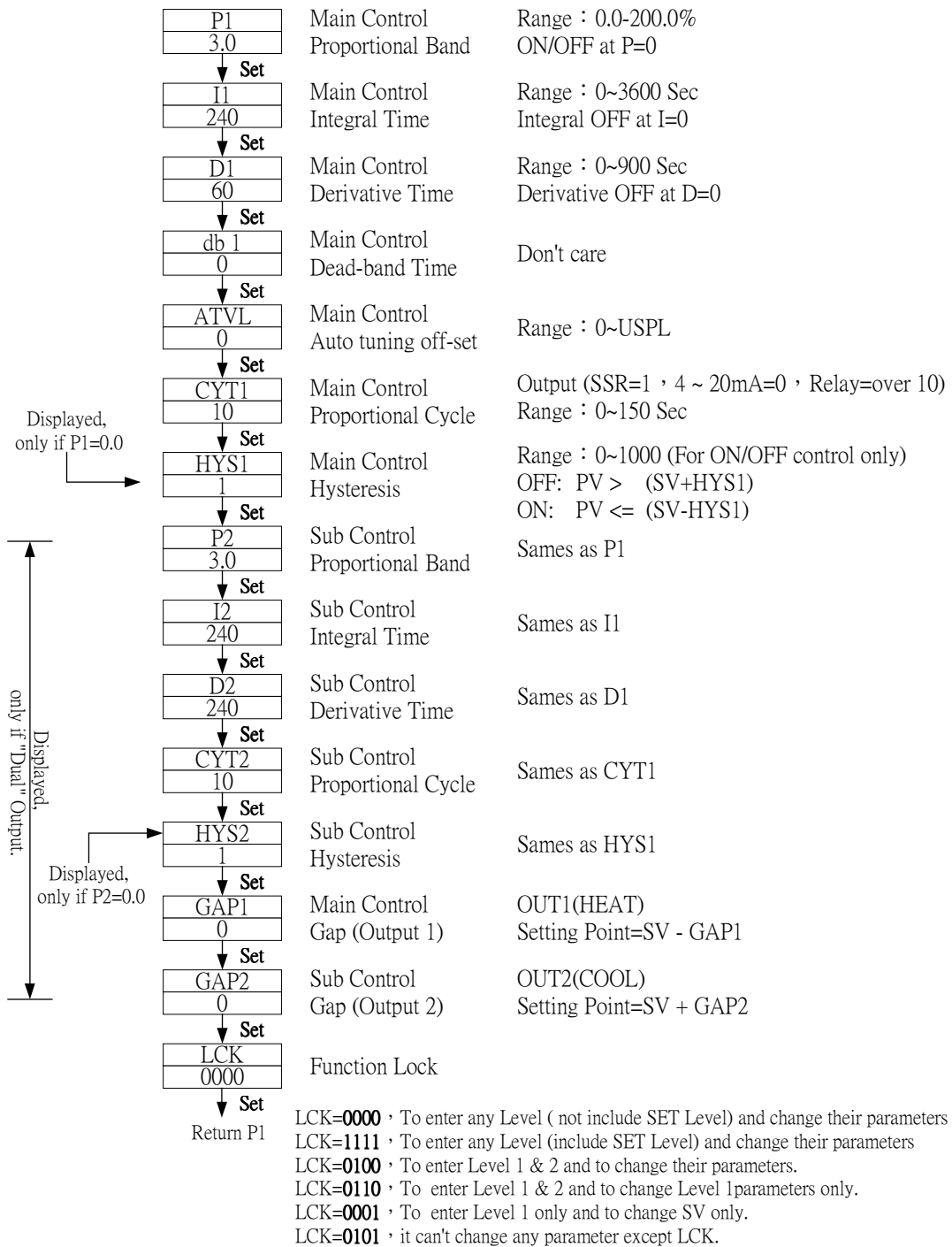

4.3 LEVEL 3 (INPUT Level)

When LCK=0000 , press SET key and SHIFT KEY  for 5 seconds to enter

LEVEL 3

INP1 K2	Main Control input selection	select the input range , refer to input selection (P.12 ~ 13)
↓ Set		
ANL1 0	Main Control Analog Zero set	It is used when INP1=AN1~AN5 Range : LSPL~USPL
↓ Set		
ANH1 5000	Main Control Analog Span set	Same as ANL1
↓ Set		
DP 0000	Decimal point	To set the position of decimal point (Only applicable when INP1=AN1~AN5)
↓ Set		
LSPL 0.0	Lower set-point limit	To set the lowest point within INP1
↓ Set		
USPL 400.0	Upper set-point limit	To set the highest point within INP1
↓ Set		
ANL2 0	Sub Control Analog Zero set	It is used as input code are AN1 to AN5 Range : LSPL~USPL
↓ Set		
ANH2 5000	Sub Control Analog Span set	Sames as ANL2
↓ Set		
ALD1 01	Alarm mode of AL1	Range:00~19 (see P.14~15)
↓ Set		
ALT1 10	Time set of Alarm 1	Range : 0~99.59 min. 0=flicker alarm , 99.59=continued , and other=on delay time Note:In program model,ALT=Alarm on time
↓ Set		
ALD2 01	Alarm mode of AL2	Range:00~19 (see P.14~15)
↓ Set		
ALT2 0	Time set of Alarm 2	Sames as ALT1
↓ Set		
ALD3 01	Alarm mode of AL3	Range:00~19 (see P.14~15)
↓ Set		
ALT3 0	Alarm 3 time set	Sames as ALT1
↓ Set		
HYSA 0	Hysteresis of alarm	Range : 0~1000
↓ Set		
CLO1 150	Main Control calibration	Calibrate the low value of output Range : LSPL~USPL(current output only)
↓ Set		

CHO1 3500	Main Control Calibration high	To calibrate the high value of output Range:0~9999(current output only)
↓ Set		
CLO2 150	Sub control Calibration low	Same as CLO1
↓ Set		
CHO2 3500	Sub control Calibration high	Same as CHO1
↓ Set		
CLO3	Transmitter control Calibration low	Same as CLO1
↓ Set		
CHO3	Transmitter control Calibration high	Same as CHO1
↓ Set		
RUCY 00	Timer of motor	Full run time of proportional motor (without potentiometer) Range : 0~150 sec.
↓ Set		
WAIT 0	Use in program for waiting continued operation	0=No Wait Other=Wait volume
↓ Set		
SETA 0000	Hysteresis for motor control	Refer to "SETA" description. (see P.22)
↓ Set		
IDNO 1	ID number (don't care)	Communication ID number
↓ Set		
BAUD 2400	Baud rate (don't care)	UART baud rate selection Range : 110~9600 BIT/sec
↓ Set		
SVOS 0	Compensate SV	Range : -1000~1000
↓ Set		
PVOS 0	Compensate PV	Range : LSPL~USPL
↓ Set		
UNIT C	Unit of PV & SV	Range : C , F , A(analog)
↓ Set		
SOFT 0.05	Soft filter (don't care)	Adjust the response time of PV (the bigger , the faster) Range : 0.05~1.00
↓ Set		
CASC	don't care	
↓ Set		
OUD HEAT	Action mode	Range : heat , cool
↓ Set		
OPAD PID	Control action	Range : PID , Fuzzy
↓ Set		
HZ 60	Frequency	Range : 50 , 60HZ
↓ Set		
Return INP1		

4.4 LEVEL 4 (SET Level)

When LCK=1111 , press SET key and SHIFT KEY  for 5 seconds to enter Level 4. There are SET 0.1 to SET 9.4 for use.

4.4.1 Display :

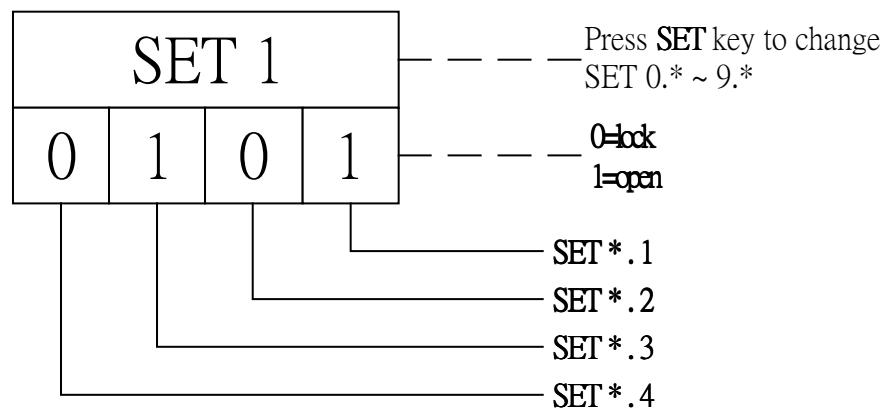

4.4.2 Function of SETs

SET	Function	SET	Function
1.1	OUTL	5.1	CLO2 , CHO2
1.2	AT	5.2	CLO3 , CHO3
1.3	AL1	5.3	RUCY , WAIT , SETA
1.4	AL2	5.4	IDNO , BAUD
2.1	AL3	6.1	SVOS
2.2	ANL1 , ANH1 , DP	6.2	PVOS
2.3	LSPL , USPL	6.3	UNIT
2.4	ANL2 , ANH2	6.4	SOFT
3.1	ALD1	7.1	CASC
3.2	ALT1	7.2	ODD
3.3	ALD2	7.3	OPAD
3.4	ALT2	7.4	HZ
4.1	ALD3		
4.2	ALT3		
4.3	HYSA		
4.4	CLO1 , CHO1		

SET	Function	Remarks
8.1	0=No repeat	Programmable Model Only
	1=Program repeat	
8.2	0=No power failure	
	1=With power failure	
8.3	0=Start from 0	
	1=Start from PV	
9.3	TRS SV	Auxiliary Output Use
9.4	TRS PV	
0.3	0=No Remote SV	
	1=Remote SV	

- When SET8.3=1 (The programmable controller will initiate the SV value to be the current PV value.) The controller will be more energy efficient, and also decreases the time needed to achieve the desired SV value. The remaining time left to reach the SV value will be shown in the parameter “TIMR”. Hence the time of countdown is related to the PV value, not related to segment setting.
- Please don't operate **SET 8.4** , otherwise the controller's process will be in confusion.

If SET8.4 is set to 0, the controller will enter into “Single Display” mode, the PV LED will not display any values. The SV LED will display both the parameter value and the setting value alternately as shown in the diagram below.

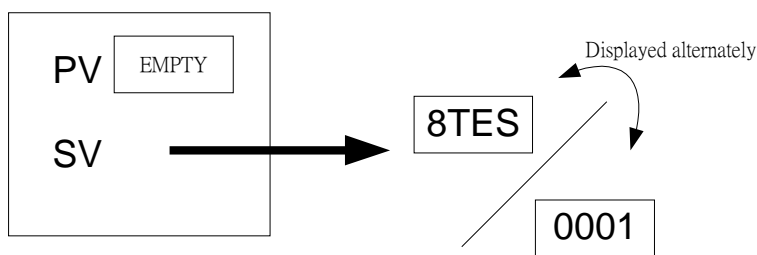

To rectify the problem please press the SHIFT KEY () and change the setting value to “0000”.

4.4.3 FUNCTION OF LCK

LCK=0000 , It can enter Level 3 (press SET +  for 5 sec.)

LCK=1111 , It can enter Level 4 (press SET +  for 5 sec.)

LCK=0100 , It can enter Level 1 & 2 and change their parameters.

LCK=0110 , It can enter Level 1 & 2 but change Level 1 parameters only.

LCK=0001 , It can enter Level 1 only and change SV only.

LCK=0101 , It can't change any parameters except LCK.

4.5 PROGRAM LEVEL (to be ordered)

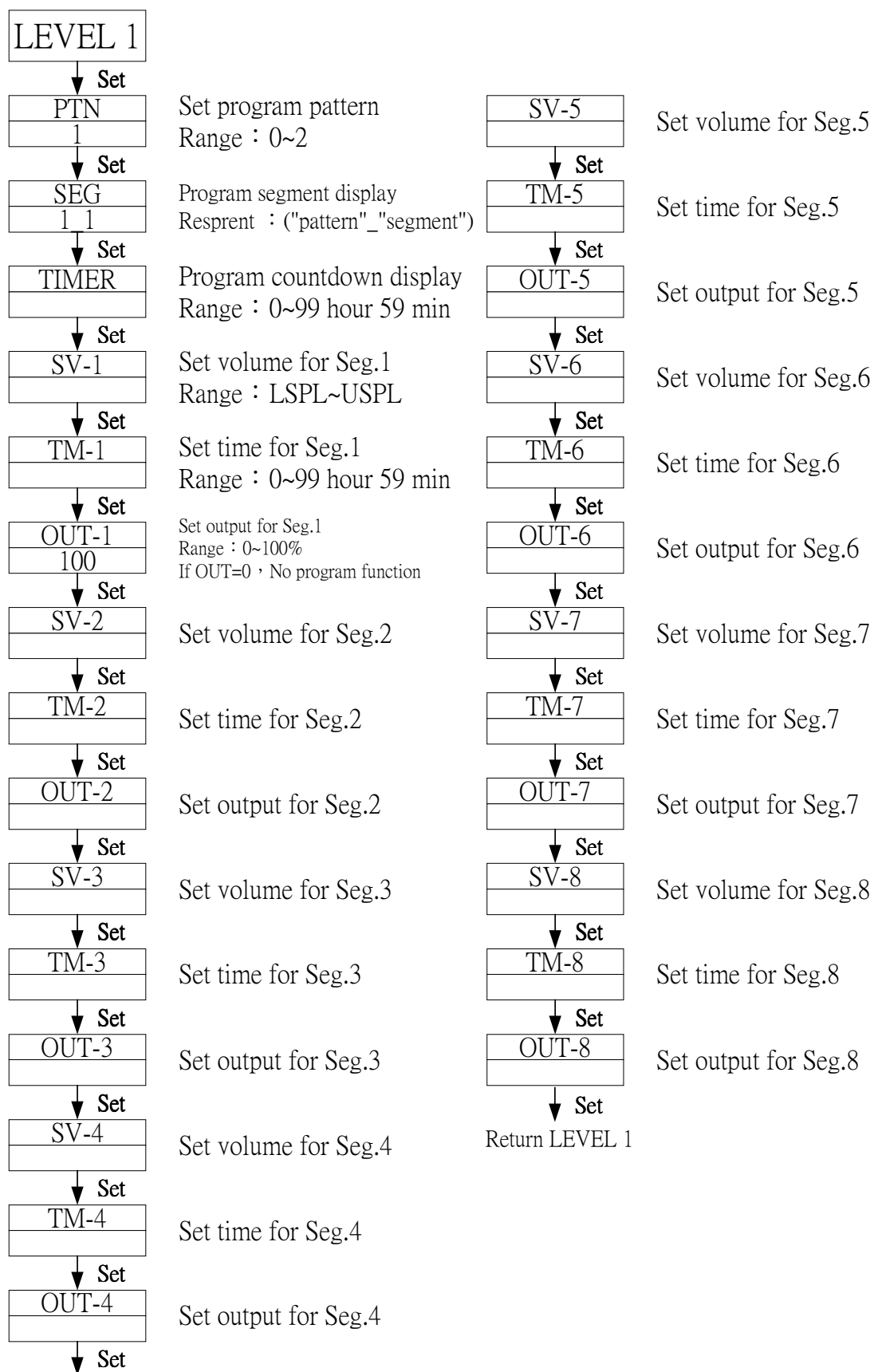

4.5.1 This program has 2 patterns , each pattern contains 8 segments.

4.5.2 Terminologies

Pattern : A program consists of some steps.

Step : A Ramp status + a Soak status.

Ramp status : The status with changing SV.

Soak status : The status with fixed SV.

4.5.3 Operating

1. "KEY" function (no changing parameter)

△ (RUN) : To start program procedure , **PRO** in panel flicker.

▽ (HOLD) : To suspend program procedure , **PRO** in panel will stop flicker but light.

△ + **SET**(JUMP) : To to jump segment.

▽ + **SET** (RESET) : To reset program procedure , **PRO** in panel will be "off".

2. Alarm Function :

If **ALD1** to be set "07"(* refer to the selection , p.14~15) ,

AL1 to be set "2"(AL1=2 , it means alarm in segment 2 end) ,

ALT1 to be set "00.10"(alarm time 10 sec.).

*In this case , when program proceeds to segment 2 end , **ALM1** relay will be on 10 sec.

3. END function :

This controller doesn't have END order, so if program procedure are less than 8 segments, please set segment's out = 0, then this program will end in last set segment. Otherwise , it will proceed 8 or 16 segments.

4. Linking Function :

PTN=1 proceed pattern 1 , contains 8 segments.

PTN=2 proceed pattern 2 , contains 8 segments.

PTN=0 linking proceed pattern 1 and 2 totally 16 segments. (set **PTN1** and **PTN2** at first , then set **PTN=0**)

5. Other function(* refer to LEVEL 4)

SET 8.1=1 program repeat.

SET 8.2=0 No power fail function.

SET 8.2=1 with power fail function (if power suspend , the controller will keep memory)

SET 8.3=0 program start from 0.

SET 8.3=1 program start from PV.

5. INPUT

5.1 Input selection (INP1)

<i>TYPE</i>	<i>CODE</i>	<i>RANGE</i>
K	K1	0.0 ~ 200.0°C / 0.0 ~392.0°F
	K2	0.0 ~ 400.0°C / 0.0 ~752.0°F
	K3	0 ~ 600°C / 0 ~1112°F
	K4	0 ~ 800°C / 0 ~1472°F
	K5	0 ~ 1000°C / 0 ~1832°F
	K6	0 ~ 1200°C / 0 ~2192°F
J	J1	0.0 ~ 200.0°C / 0.0 ~392.0°F
	J2	0.0 ~ 400.0°C / 0.0 ~752.0°F
	J3	0 ~ 600°C / 0 ~1112°F
	J4	0 ~ 800°C / 0 ~1472°F
	J5	0 ~ 1000°C / 0 ~1832°F
	J6	0 ~ 1200°C / 0 ~2192°F
R	R1	0 ~ 1600°C / 0 ~2912°F
	R2	0 ~ 1796°C / 0 ~3216°F
S	S1	0 ~ 1600°C / 0 ~2912°F
	S2	0 ~ 1796°C / 0 ~3216°F
B	B1	0 ~ 1820°C / 0 ~3308°F
E	E1	0 ~ 800°C / 0 ~1472°F
	E2	0 ~ 1000°C / 0 ~1832°F
N	N1	0 ~ 1200°C / 0 ~2192°F
	N2	0 ~ 1300°C / 0 ~2372°F
T	T1	-199.9 ~ 400.0°C / -199.9 ~752.0°F
	T2	-199.9 ~ 200.0°C / -199.9 ~392.0°F
	T3	0.0 ~ 350.0°C / 0.0 ~662.0°F
W	W1	0 ~ 2000°C / 0 ~3632°F
	W1	0 ~ 2320°C / 0 ~2372°F
PL II	PL 1	0 ~ 1300°C / 0 ~2372°F
	PL 2	0 ~ 1390°C / 0 ~2534°F
U	U1	-199.9 ~ 600.0°C / -199.9 ~999.9°F
	U2	-199.9 ~ 200.0°C / -199.9 ~392.0°F
	U3	0.0 ~ 400.0°C / 0.0 ~752.0°F

TYPE	CODE	RANGE
L	L1	0 ~ 400°C / 0 ~ 752°F
	L2	0 ~ 800°C / 0 ~ 1472°F
JIS PT100	JP 1	-199.9 ~ 600.0°C / -199.9 ~ 999.9°F
	JP 2	-199.9 ~ 400.0°C / -199.9 ~ 752.0°F
	JP 3	-199.9 ~ 200.0°C / -199.9 ~ 392.0°F
	JP 4	0 ~ 200°C / 0 ~ 392°F
	JP 5	0 ~ 400°C / 0 ~ 752°F
	JP 6	0 ~ 600°C / 0 ~ 1112°F
DIN PT100	DP 1	-199.9 ~ 600.0°C / -199.9 ~ 999.9°F
	DP 2	-199.9 ~ 400.0°C / -199.9 ~ 752.0°F
	DP 3	-199.9 ~ 200.0°C / -199.9 ~ 392.0°F
	DP 4	0 ~ 200°C / 0 ~ 392°F
	DP 5	0 ~ 400°C / 0 ~ 752°F
	DP 6	0 ~ 600°C / 0 ~ 1112°F
JIS PT50	JP.1	-199.9 ~ 600.0°C / -199.9 ~ 999.9°F
	JP.2	-199.9 ~ 400.0°C / -199.9 ~ 752.0°F
	JP.3	-199.9 ~ 200.0°C / -199.9 ~ 392.0°F
	JP.4	0 ~ 200°C / 0 ~ 392°F
	JP.5	0 ~ 400°C / 0 ~ 752°F
	JP.6	0 ~ 600°C / 0 ~ 1112°F
AN1	AN1	-10 ~ 10mV / -1999~9999
AN2	AN2	0 ~ 10mV / -1999~9999
AN3	AN3	0 ~ 20mV / -1999~9999
AN4	AN4	0 ~ 50mV / -1999~9999
AN5	AN5	10 ~ 50mV / 1999~9999

* The initial set in factory is "K2" without any certain requirement

6. ALARM

6.1 Alarm function selection









CODE	DESCRIPTION	INHIBIT
00 / 10	None	
01	Deviation high limit alarm	YES
11	Deviation high limit alarm	NO
02	Deviation low limit alarm	YES
12	Deviation low limit alarm	NO
03	Deviation high / low limit alarm	YES
13	Deviation high / low limit alarm	NO
04 / 14	Deviation high / low limit range alarm	NO
05	Absolute value high limit alarm	YES
15	Absolute value high limit alarm	NO
06	Absolute value low limit alarm	YES
16	Absolute value low limit alarm	NO
07	Segment end alarm (use for program model only)	-
17	Program run alarm (use for program model only)	-
08	System error alarm-on	-
18	System error alarm-off	-
09		-
19	On delay timer alarm	-

Note : the word “**INHIBIT**” means that alarm does not work at the first time.

6.2 Alarm action description

▲ : SV

△ : Alarm set value
(inhibit means alarm doesn't work at the first time)

00 10	Non
01	Deviation high alarm inhibit 
11	Deviation high alarm no inhibit 
02	Deviation low alarm inhibit 
12	Deviation low alarm no inhibit 
03	High low alarm inhibit 
13	High low alarm no inhibit 
04 14	Band alarm 
05	Absolute high alarm inhibit 

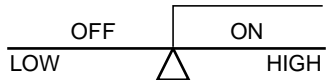
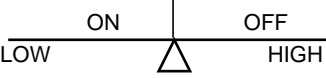
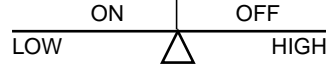
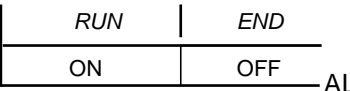
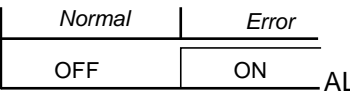
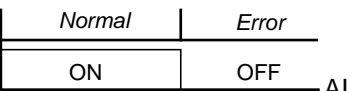
15	Absolute high alarm no inhibit 
06	Absolute low alarm inhibit 
16	Absolute low alarm no inhibit 
07	Segment end alarm (use for PFY Model only) (1) ALD1~3 , set 07 (2) AL1~3=alarm segment No.set (3) ALT1~3 if set 0=flicker alarm ALT1~3 if set 99.59=continued alarm ALT1~3 if set others=ON delay time
17	Program Run alarm(Refer to SETA.4 , P.23) (use for PFY Model only) 
08	System error alarm - ON 
18	System error alarm - OFF 
09	
19	On delay timer When PV=alarm SV , it keeps a certain period(set time)before alarm action. Range:00H.00M~99H.59M

7. Modification of input “TC” \rightleftharpoons “RTD”(on PC board)

If the controller needs modification from **TC** or **mV** to **RTD** type , please make PAD short on PC board back as following diagram and changing input selection. On the contrary , modify from **RTD** to **TC** or **mV** , make PAD open.

96×96 , 48×96 , 96×48
(PC Board)

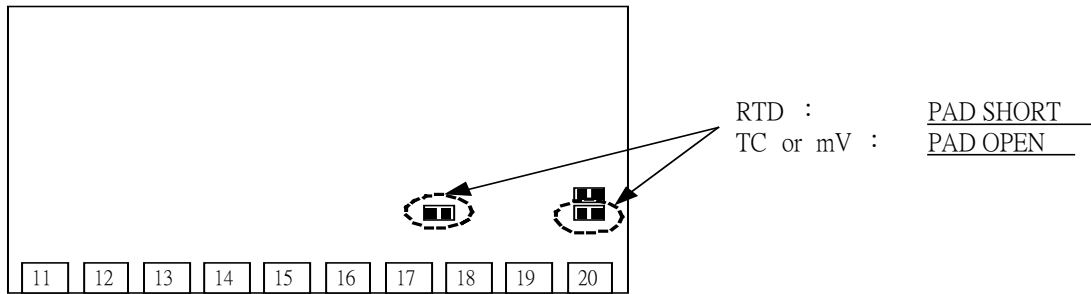

72×72
(PC Board)

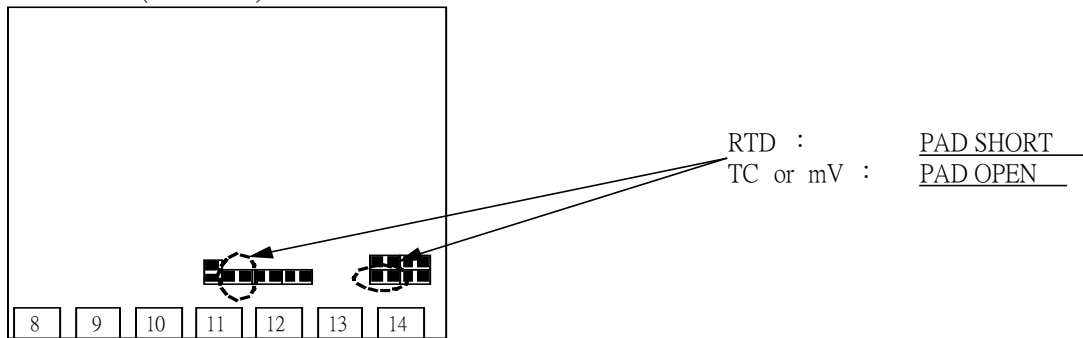

48×48
(PC Board)

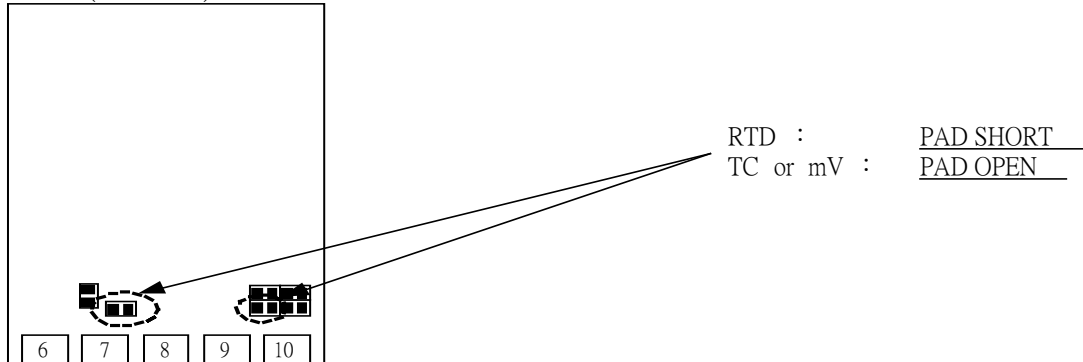

8.Modification of output “Relay” \rightleftharpoons “SSR” \rightleftharpoons “4~20mA”

It just needs to change a module at the same position , and modify parameter **CYT1** in LEVEL 2 .

9. Modification of output

“HEAT/ALARM” \rightleftarrows “HEAT/COOL” (on PC board)

HEAT / ALARM

96×96 , 48×96 , 96×48
(PC Board)

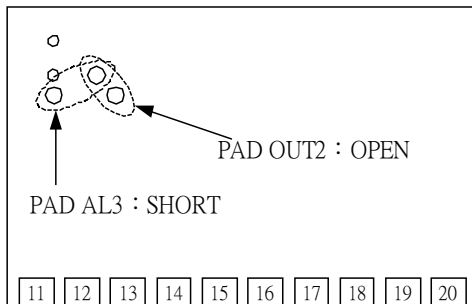

72×72
(PC Board)

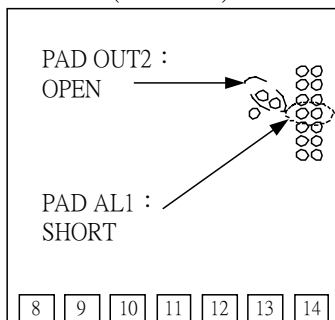

48×48
(PC Board)

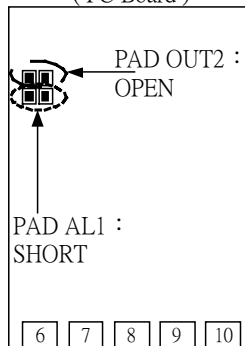

HEAT / COOL

96×96 , 48×96 , 96×48
(PC Board)

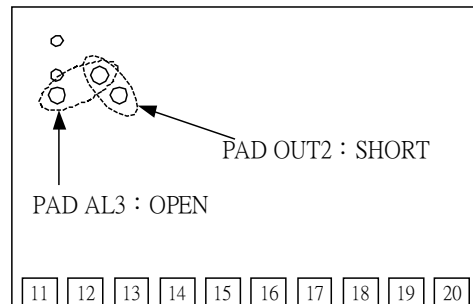

72×72
(PC Board)

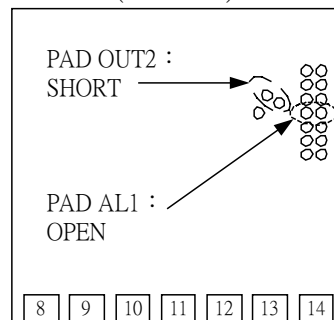

48×48
(PC Board)

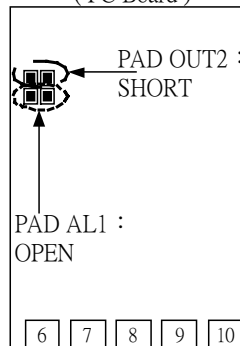

10. Modification of INPUT : 0~1V , 0~5V , 0~10V , mA

10.1 Hardware part :

	96×96 , 48×96 , 96×48	72×72	48×48
INPUT(+)	PIN 17	PIN 11	PIN 7
INPUT (-)	PIN 20	PIN 14	PIN 10

- 1V , 5V , 10V : (R4 use 100Ω)
- mA : (R3 use 100Ω , R5 use 2.4Ω , S3&S5 SHORT)
- 0 ~ 1V : (R1 use 2KΩ , S1 & S4 SHORT)
- 0 ~ 5V : (R2 use 10KΩ , S2 & S4 SHORT)
- 0 ~ 10V : (R3 use 22KΩ , S3 & S4 SHORT)

96×96 , 48×96 , 96×48
(PC Board)

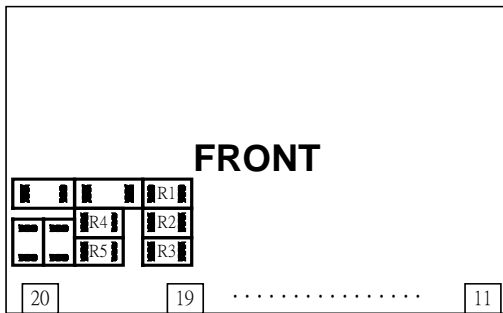

96×96 , 48×96 , 96×48
(PC Board)

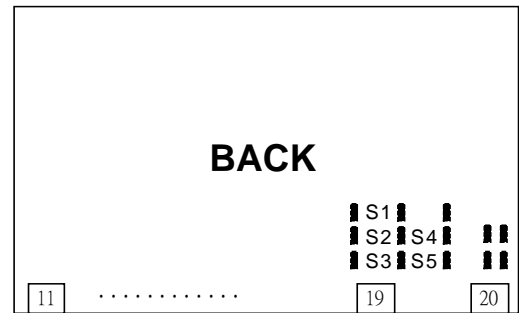

72×72
(PC Board)

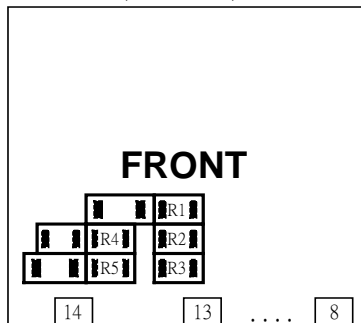

72×72
(PC Board)

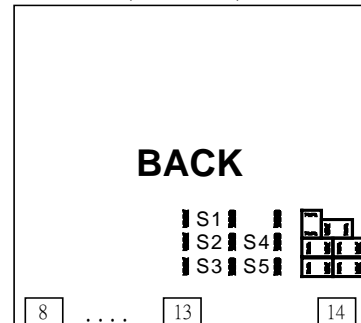

48×48
(PC Board)

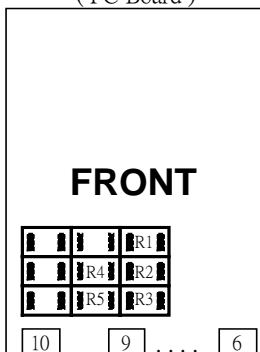

48×48
(PC Board)

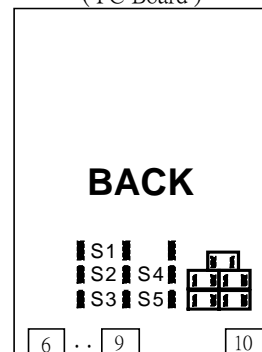

10.2 Software part (Calibrate input)

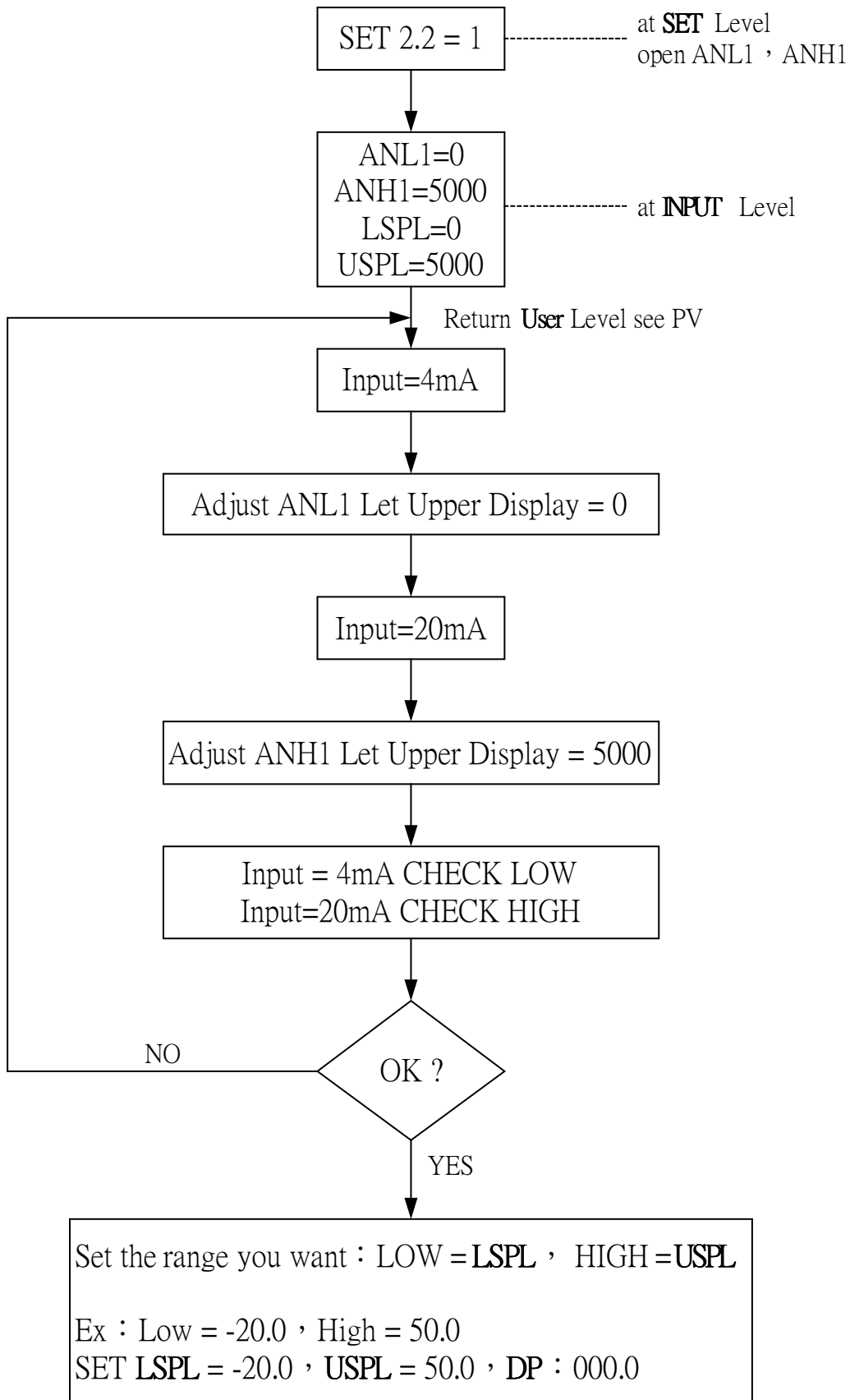

11. Special Function Description :

11.1 LEVEL 4 (Set Level)

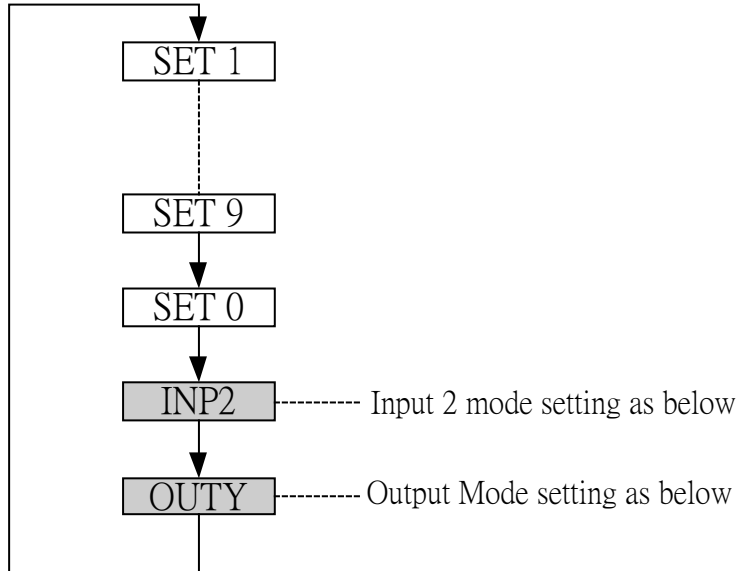

11.1.1 Second input mode

INP2=0 None (FY MODEL ONLY)

INP2=1 10~50mV / 4~20mA / 2~10V

INP2=2 0~50mV / 0~20mA / 0~10V

*Second Input is for Remove SV function, but the PFY model `s SV can only be controlled by the program, so INP2=0 is not applicable.

11.1.2 Output mode

OUTY=0 Single Output

OUTY=1 Double Output

OUTY=2 None

OUTY=3 Motor Valve

OUTY=4 1 ϕ SCR (Single Phase Control)

OUTY=5 3 ϕ SCR (Three Phase Control)

11.2 RAMP & SOAK (Only Applicable for FY MODEL)

11.2.1 RAMP :

- I. Please set "SET2.1=1"(Display AL3) , "SET4.1=1" (Display ALD3)
- II. ALD3=9 at INPUT Level
- III. RAMP menu will be displayed (replace AL3)

RAMP
0000

Range : 00.00 ~ 99.99
 Unit : °C / min
 (If RAMP not used, set ALD3=0)

11.2.2 SOAK :

- I. ALD1 / ALD2=19
- II. AL1 / AL2 will be display

AL1
00.00

Range : 00.00 ~ 99.59(Hour.Minute)

11.2.3 Example :

SV=100°C , RAMP=10.00 (°C/min) , AL1=00.10 min , PV=25°C

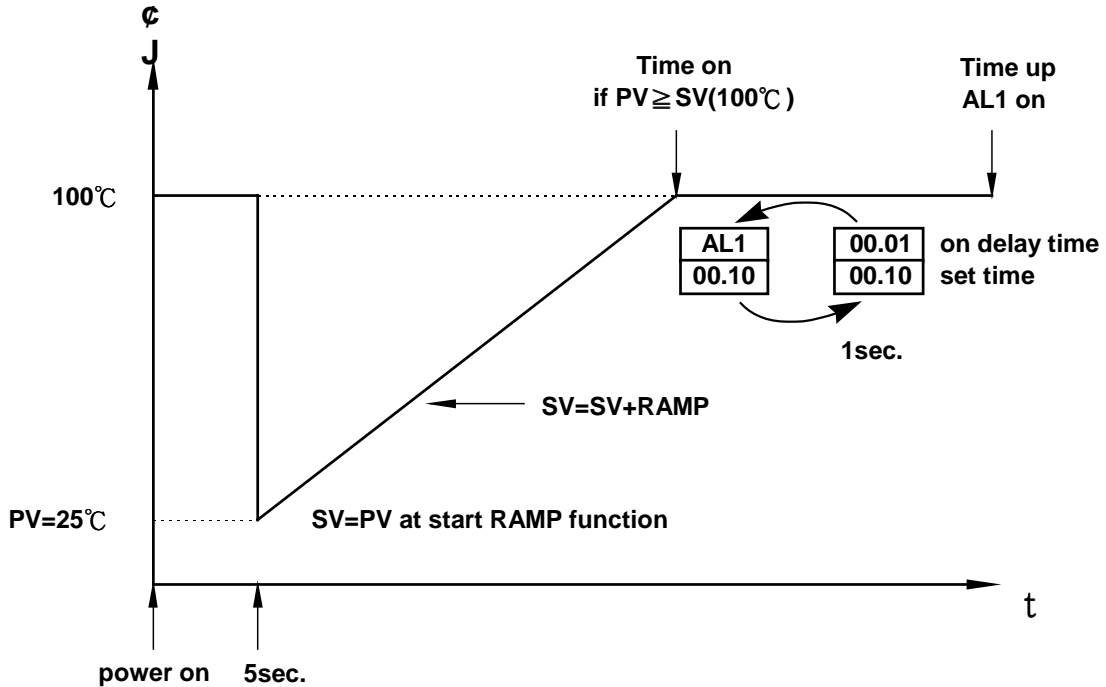

11.3 REMOTE SV (Only applicable for FY MODEL)

11.3.1 Hardware must be mounted

11.3.2 Set INP2 to 1 or 2 (calibration use ANL2 , ANH2)

11.3.3 SET 0.3=0 means local SV

11.3.4 SET 0.3=1 means remote SV from Input 2 channel

11.4 Alarm Time ALT1/ALT2/ALT3 description (FY MODEL ONLY)

1. ALT1=0 means flicker if AL1 is on
2. ALT1=99.59 means alarm if AL1 is on
3. ALT1=00.01 ~ 99.58 means AL1 is on delay timer(* use for large EMI affect controller)

11.5 Renew function "HYSM" → "SETA"

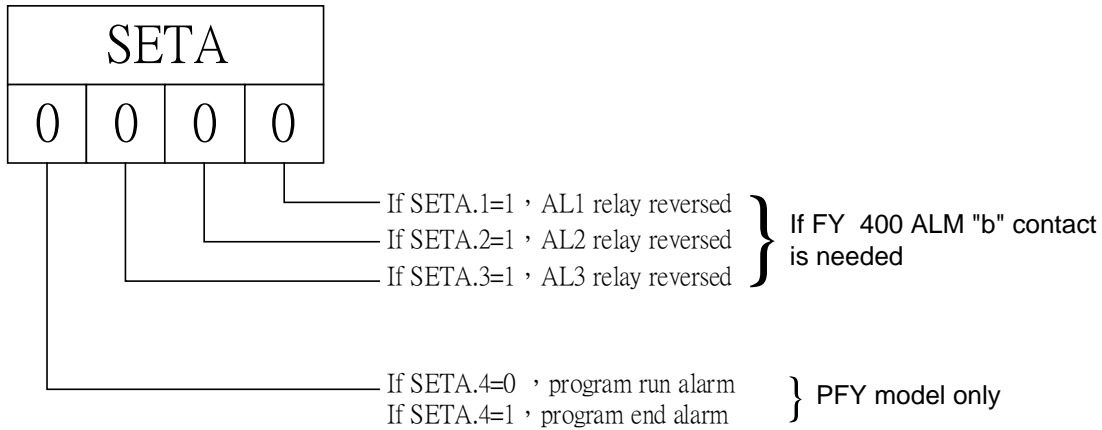

11.6 Function SET8

11.6.1 SET8.1=0 None

SET8.1=1 program repeat (PFY model)

11.6.2 SET8.2=0 Non (PFY only)

SET8.2=1 Power failure access

11.6.3 SET8.3=0 Zero start (PFY only)

SET8.3=1 PV start (PFY only)

11.6.4 SET8.4=0 None

SET8.4=1 display will be transferred to single display (Don't set this Bit) *SET8=0000 can return double display

11.7 Function SET9

- 11.7.1 SET9.1=0 None
- SET9.1=1 PV / SV switching (use for single display so please don't set this Bit.)
- 11.7.2 SET9.2=0 None
- SET9.2=1 PFY models : Timer change from H.M to M.S
- 11.7.3 SET9.3=0 None
- SET9.3=1 Transmission SV
- 11.7.4 SET9.4=0 None
- SET9.4=1 Transmission PV

11.8 SET0

- 11.8.1 SET0.1=0 None
- SET0.1=1 TTL communication SV output
- 11.8.2 SET0.2=0 None
- SET0.2=1 Rate for AL3 (ALD3=0) (see Application 1 , P.25)
- 11.8.3 SET0.3=0 None
- SET0.3=1 Remote SV
- 11.8.4 SET0.4=0 Motor Valve close = "b" out
- SET0.4=1 Motor Valve close = "a" out

11.9 WAIT at INPUT Level

- WAIT=0 means "no wait"
- WAIT ≠ 0 means "wait"

12.Panel cut & Outline Dimension :

12.1 Panel Cut Dimension(Units : mm)

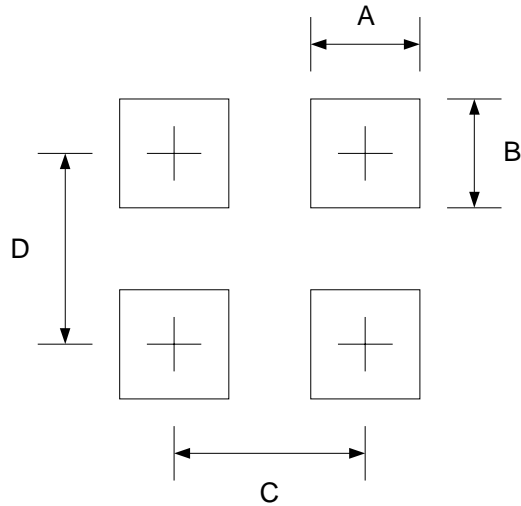

	A	B	C	D
FY400	44.5+0.5	44.5+0.5	65	70
FY600	90.5+0.5	44.5+0.5	111	70
FY700	68.5+0.5	68.5+0.5	89	94
FY800	44.5+0.5	90.5+0.5	65	116
FY900	90.5+0.5	90.5+0.5	111	116

12.2 Outline Dimension (Units : mm)

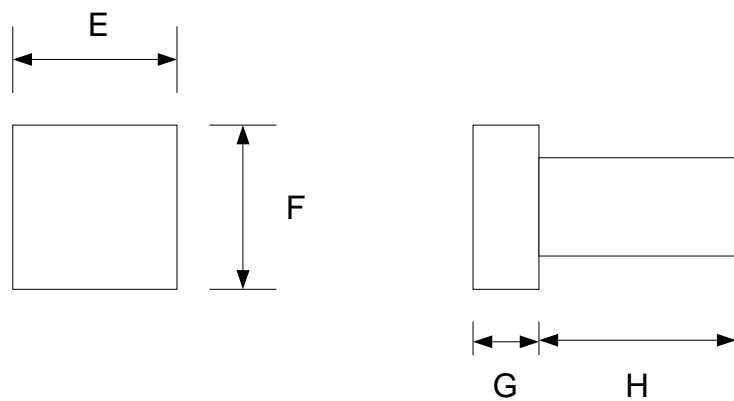

	E	F	G	H
FY400	50	50	17	80
FY600	96	50	17	80
FY700	74	74	17	80
FY800	50	96	17	80
FY900	96	96	17	80

Application

App1. TTL communication : SV output & RATE function

➤ **Open RATE function (use for slave)**

11.10 Open Rate : SET0.2=1

11.11 Open AL3 : SET2.1=1

11.12 Open ALD3 : SET4.1=1

11.13 ALD3=0 at INPUT Level

11.14 Slave SV = (RATE ÷ 9999) × master SV

➤ **Example :**

Connect Diagram

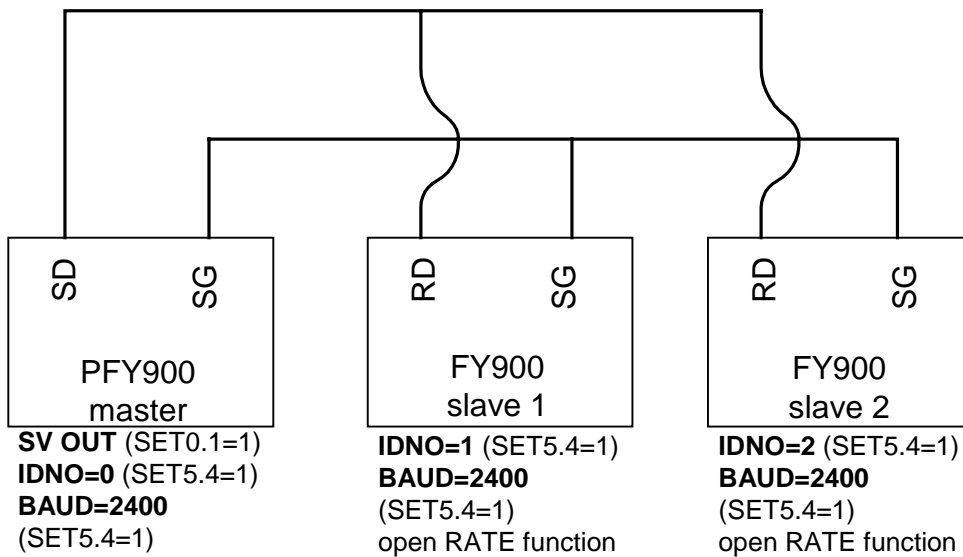

Time Chart

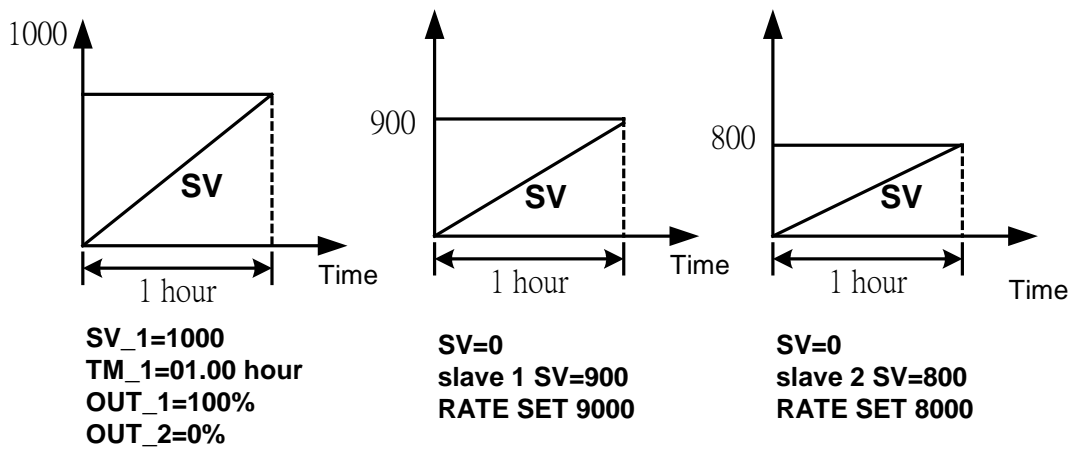

(All reach to the max value at the same time)

App2. Single Phase Control (for SCR module)

- Available Models : FY900 / PFY900 , FY700 / PFY700
- Data Change : OUTY=4
 CLO1=0 , CHO1=4500 if use for resistance load
 CLO1=0 , CHO1=4000 if use for inductor load

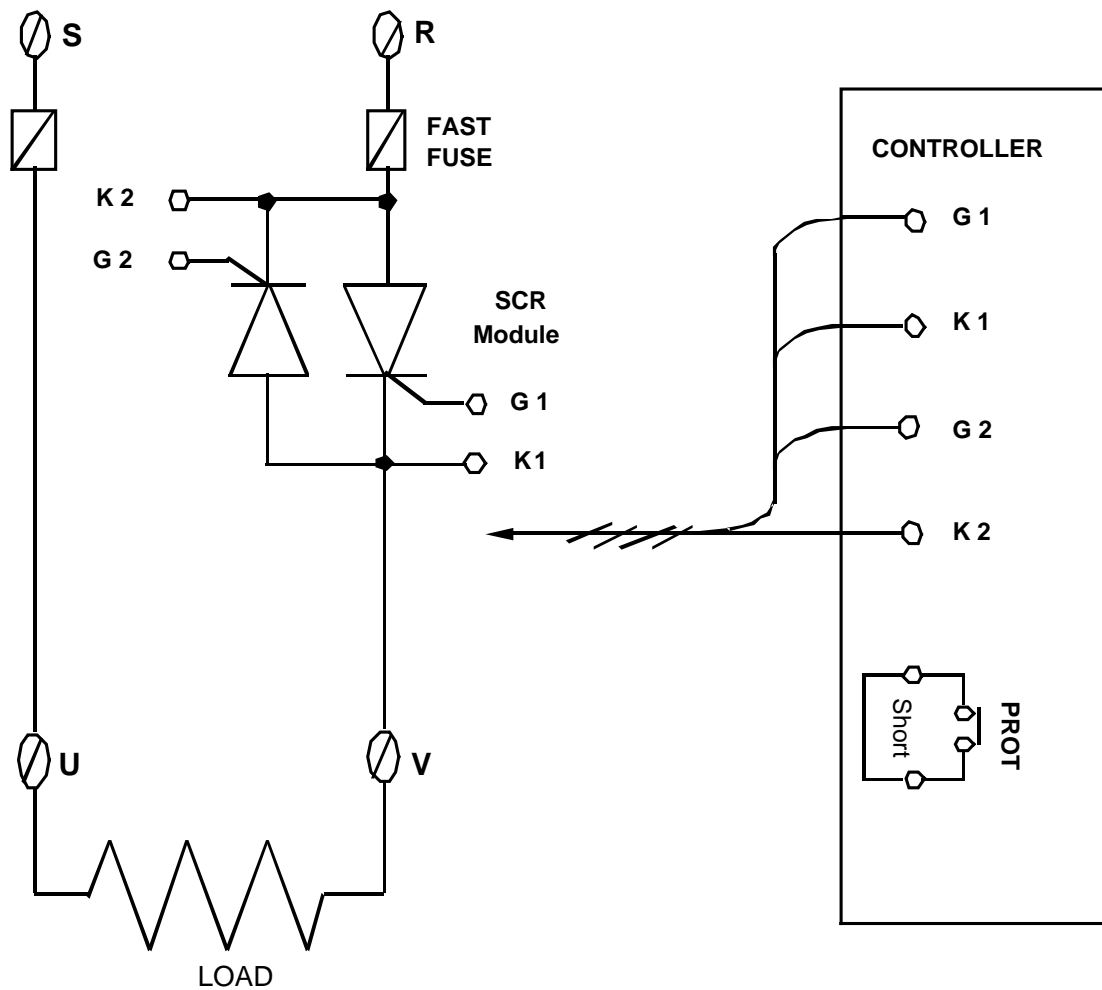

** Controller source phase must be same as load source phase

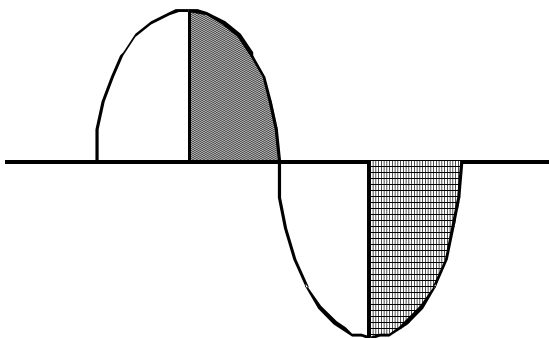

App3. Single Phase Control (for TRIAC module)

- Available Models : FY900 / PFY900 , FY700 / PFY700
- Data Change : OUTY=4
 CLO1=0 , CHO1=4500 if use for resistance load
 CLO1=0 , CHO1=4000 if use for inductor load

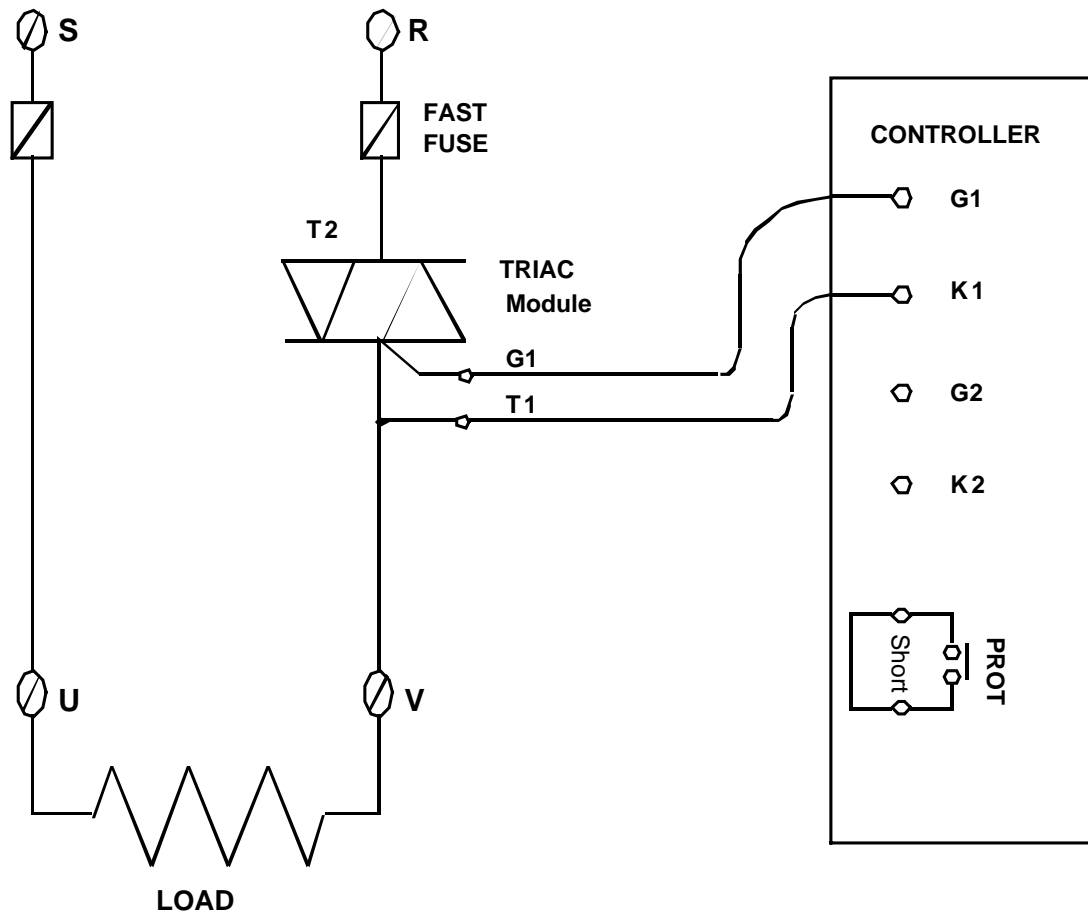

** Controller source phase must be same as load source phase

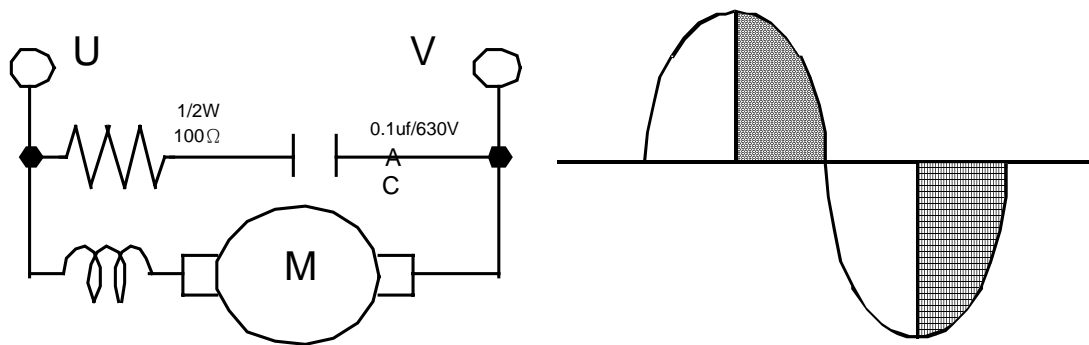

App4. Three Phase Control

- Available Models : FY900 / PFY900
- Data Change : OUTY=5
CLO1=0 , CHO1=4500 only if use for resistance load

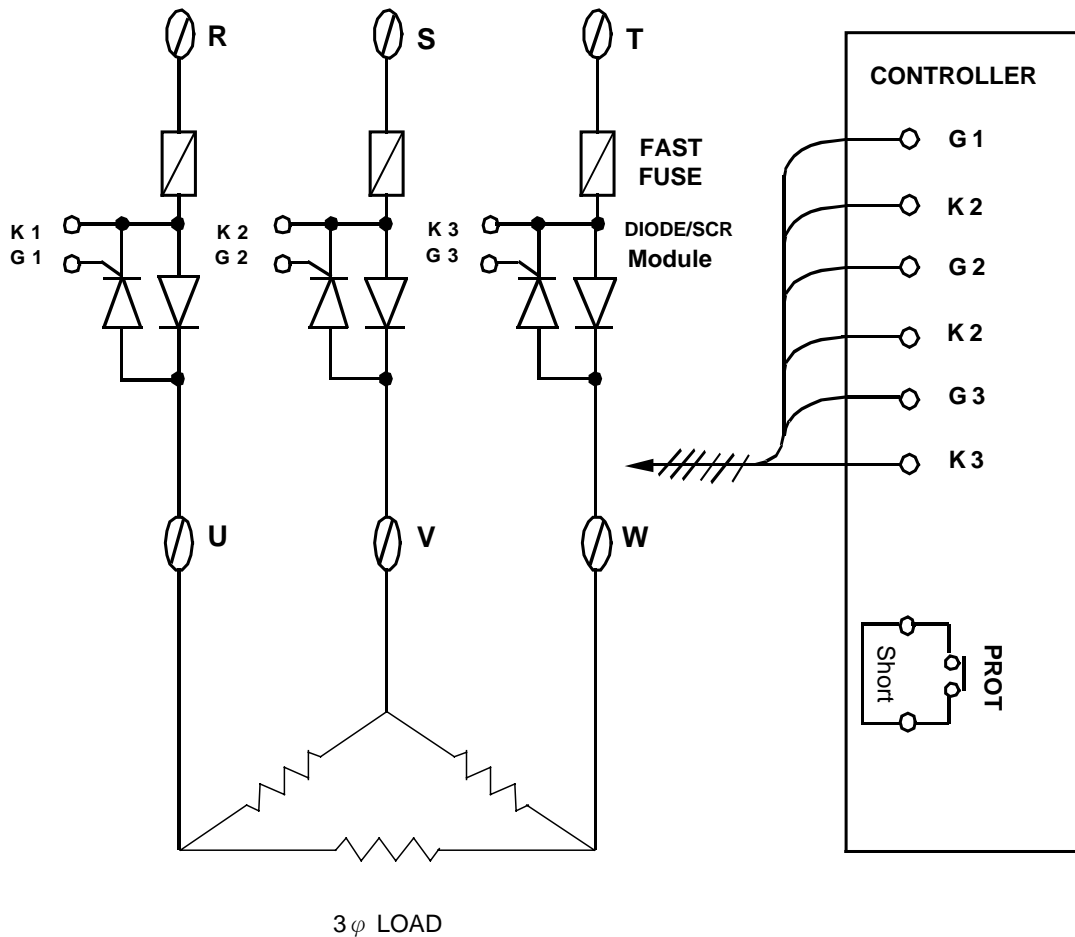

App5. Single Phase Zero Control

- Available Models : FY900 / PFY900 , FY700 / PFY700
FY400 / PFY400
- Data Change : OUTY=0
CYT1=1

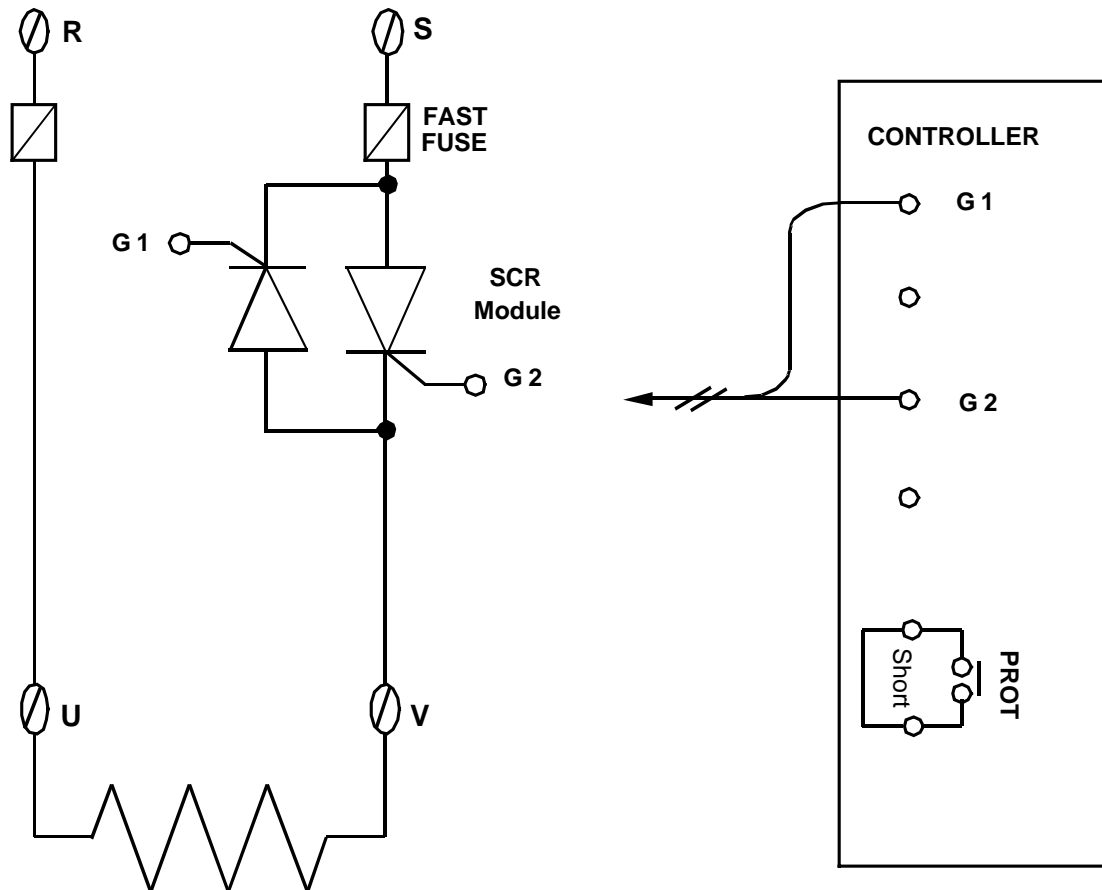

TIME CHART:

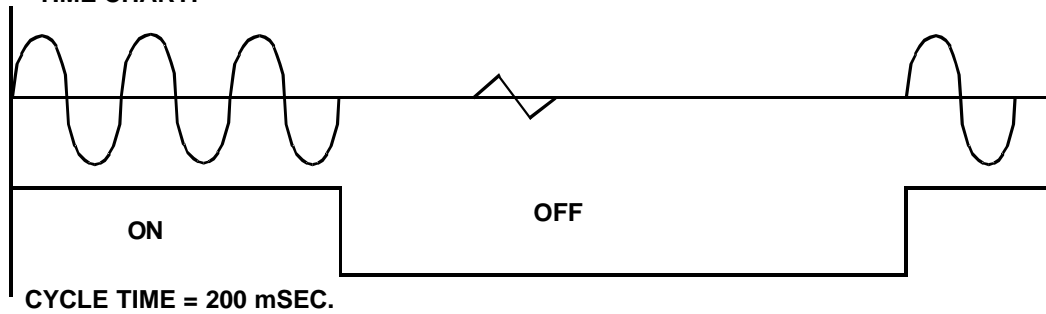

App6. Three Phase Zero Control

- Available Models : FY900 / PFY900
- Data Change : OUTY=0
CYT1=1

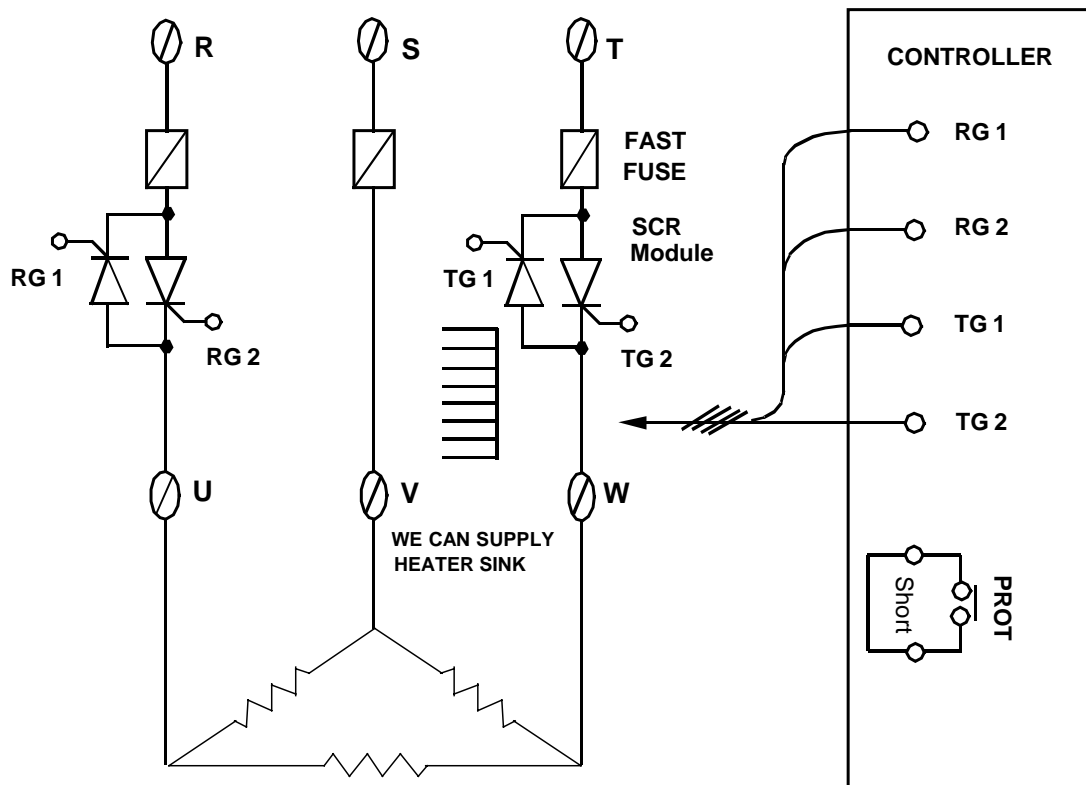

TIME CHART:

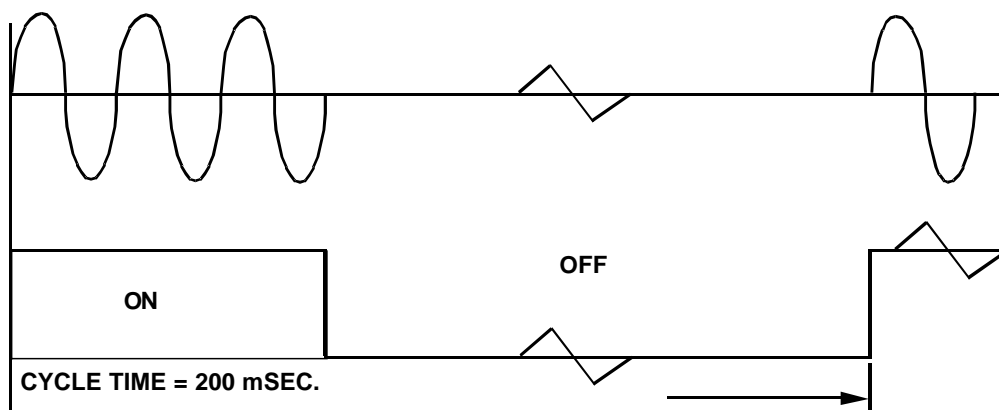

App7. Motor Valve Control

- Available Models : FY900 / PFY 900 , FY800 / PFY800
FY400/PFY400 , FY700 / PFY700
FY600 / PFY600
 - Data Change : OUTY=3
CYT1=1 ~ 100sec.(Manufacturing default
setting "5" sec.)
RUCY=5 ~ 200 sec.
1. CYT1 is the cycle time of Open / Close
 2. RUCY is the running time of motor valve 0 ~ 100%

MOTOR VALVE

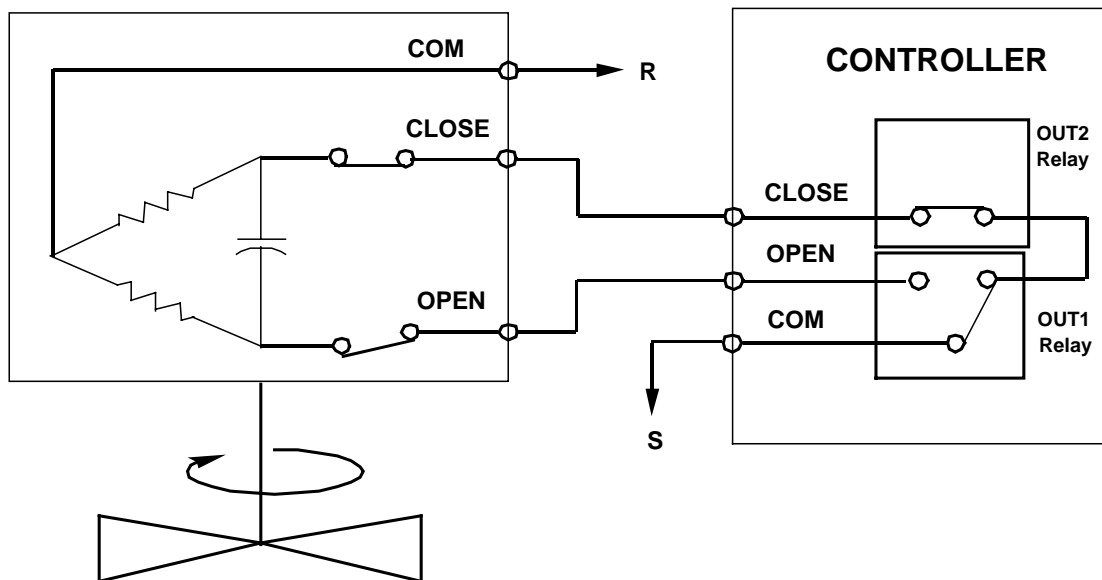

App8. RS485 Communication

RS485 Connection Diagram

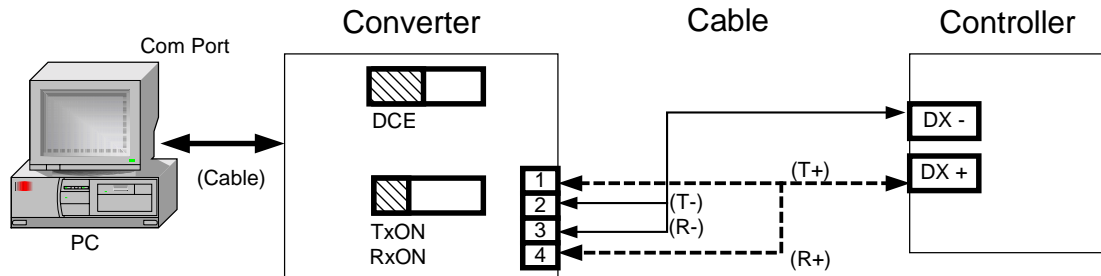

NOTE:

- 1.The length of the cable line between Converter and Controller can't exceed 1.2 KM.
- 2.One Com Port can be connected up to a maximum of 30 Controllers.
- 3.Ensure that the Controller's IDNO and BAUD have the same value as the software's setting.
- 4.For the software communication format please refer to the "Protocol" file in the CD.

App9. RS232 Communication

RS232 Connection Diagram

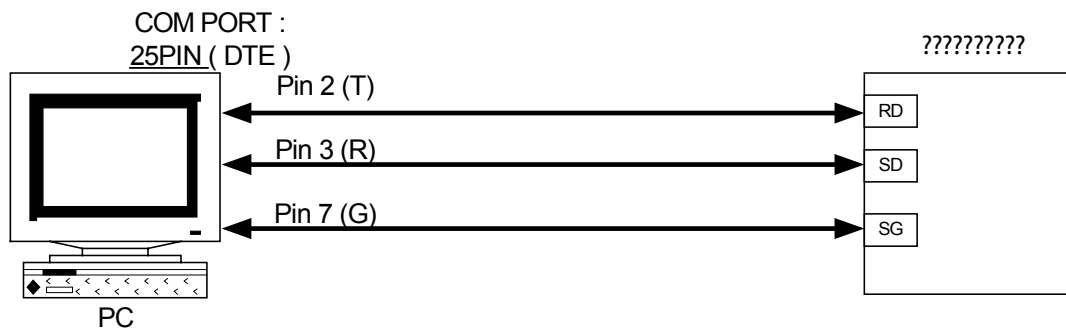
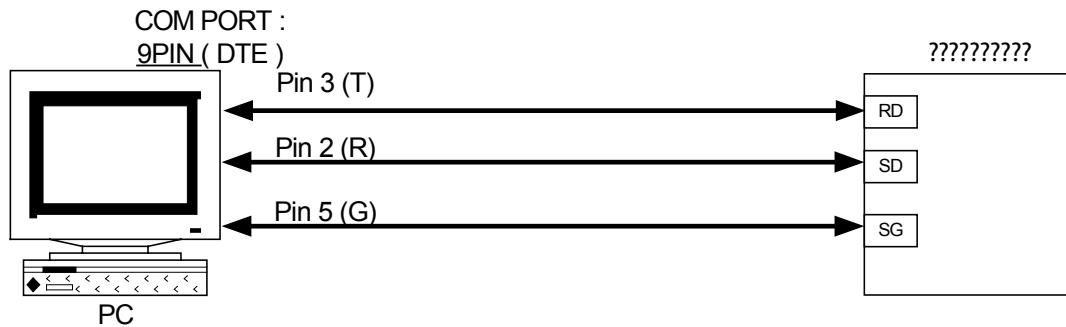

NOTE:

- 1.The length of the cable line can't exceed 15 meter.
- 2.One Com Port can only be connected to one controller.If more than one controller is connected to one Com Port? communication will be failed.
- 3.Ensure that the controller's IDNO and BAUD have the same value as the software's setting.
- 4.For the software communication format please refer to the "Protocol" file in the CD.



National Plastic Heater Sensor & Control Co.

phone: 416.491.8436 toll free: 1.877.674.9744 fax: 416.491.2433
Toronto, Ontario Canada e-mail: sales@nphheaters.com website www.nphheaters.com